

widi aribowo - icvee 2020 revisi

by Widi Aribowo

Submission date: 06-Oct-2020 12:06PM (UTC+0700)

Submission ID: 1406757486

File name: 269-IEEE.doc (494K)

Word count: 2146

Character count: 12293

Tuning of Power System Stabilizer Using Cascade Forward Backpropagation

Widi Aribowo
Department Of Electrical Engineering
Universitas Negeri Surabaya
Surabaya, Indonesia
widiaribowo@unesa.ac.id

Bambang Suprianto
Department Of Electrical Engineering
Universitas Negeri Surabaya
Surabaya, Indonesia
bambangsuprianto @unesa.ac.id

Supari Muslim
Department Of Electrical Engineering
Universitas Negeri Surabaya
Surabaya, Indonesia
supari@unesa.ac.id

Unit Three Kartini
Department Of Electrical Engineering
Universitas Negeri Surabaya
Surabaya, Indonesia
unit three @unesa.ac.id

munoto
Department Of Electrical Engineering
Universitas Negeri Surabaya
Surabaya, Indonesia
munoto@unesa.ac.id

I. G. P. Asto Buditjahjanto
Department Of Electrical Engineering
Universitas Negeri Surabaya
Surabaya, Indonesia
asto@unesa.ac.id

Abstract—The Overshoot and time settling of the electromechanical are a serious problem for tuning PSS. Cascade Forward Backpropagation (CFBNN) has a topology similar to Feed Forward Back Propagation. It is using Backpropagation to updating weights. The Network has the advantage that it is a bypass. That connects the input layer that passes through the hidden layer. The networks are dynamic. The research was implemented to oppose conventional PSS (C-PSS) and Cascade Forward Backpropagation Neural Networks (CFBNN-PSS). The focus of the research was on rotor angle and angular frequency. The result of proposed CFBNN has better performance to reduce of overshoot angular frequency and rotor angle. The CFBNN PSS can reduce overshoot of angular frequency until 90.7% with faster time-settling

Keywords— PSS, Artificial Intelligence, Cascade Forward Backpropagation, Neural Network, Heffron Phillips

I. INTRODUCTION

Electric power systems are operated in a steady-state frequently interference. The disorder was caused by switching operations, detaching plants, shorting circuits, loading suddenly, etc. It can interfere with the harmony of the system. It would influence the generator stability and can result in the synchronization system decreases.

Electric power systems are grouped into three groups namely generating systems, transmission systems and distribution systems. The generation system is a place convert mechanical energy into electrical energy.

Small load changes will affect the harmony of the electrical system. The ability of the system to respond to the system to these changes is called the dynamic stability of the electric power system. Changes in generator rotor speed and generator terminal voltage are sometimes influenced by small changes in load. The speed of the generator rotor will be swinging around the synchronous speed and the generator voltage around the nominal value. A generator is said to be stable if the rotor speed returns to synchronous speed and convergent voltage to certain value around the nominal value after the disturbance (change of load),

The C-PSS (conventional PSS) is commonly planned using a linear model of the system for a fixed employing point [1]. Power System Stabilizers (PSS) are providing a damping torque with the goal to minimize oscillations

generated by external disturbance. The key to reducing low oscillations in the generator is tuning of the PSS [2-3]. Classical control using linear modeling with parameters remains a popular concept in PSS. Obstacles that often arise in electrical systems are loads that are non-linear and change every time

However, because of the nonlinearity the system as well as parameter uncertainty, conventional PSS cannot suitably to minimize low-frequency swing and ineffective to supply a solid performance. Some researchers have developed some of the latest methods in PSS design. Berbagai teknik dihadirkan yaitu Particle Swarm Optimization [4], Cuckoo Search Algorithm [5], Fuzzy logic [6], Artificial bee colony [7], dan cultural algoritma [8].

Conventional PSS design cannot guarantee the harmony of the electrical system due to the influence of increasingly complex system dynamics. Therefore, the design of high performance PSS is needed with the latest method. This study discusses the PSS design using the CFBNN algorithm. The Power System Stabilizer using CFBNN is employed in a single-machine system. CFBNN-PSS results will be compared with conventional PSS and Elman-recurrent neural networks. The focus of this research is the rotor angle and angular frequency of the generator output.

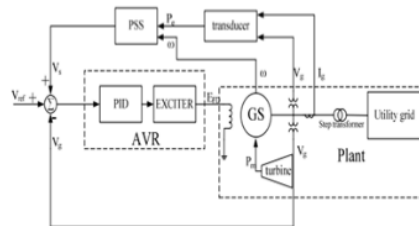

Fig. 1. System structure[10]

II. POWER SYSTEM STABILIZER

Electromechanical oscillation and inter-area oscillation control which is popularly used is the power system stabilizer (PSS) [9]. The high gain from AVR, HVDC converter or Static Var Compensator (SVC) can cause low-frequency oscillations with negative attenuation. It is a dynamic stability problem.

AVR negative attenuation is compensated using PSS. The principal purpose of the PSS is to expand the stability limit with controlling generator excitation by providing rotor damping, especially on interconnected machines. To produce damping of the torque component, the pss must produce a signal that is used to regulate the excitation of the generator.

PSS has three primary components. Gain is the amount of attenuation generated by the PSS and can be adjusted to the maximum state. The washout has a function as a high pass filter that is used to reduce oscillations. Phase compensation which serves to perform lagging phases.

III. CASCADE FORWARD BACKPROPAGATION

The concept of cascade back-propagation (CFB) is to combine backpropagation and cascade-correlation algorithms [11]. This network is formed from input, hidden, and output [12]. The conceptual of CFB is to accelerate learning on neural networks. CFB presented by Scott Fahlman at Carnegie Mellon in 1990.

Cascade forward backpropagation and feed-forward architectures are similar [13]. Cascade forward backpropagation has a dynamic character[14]. The weighting connections of Cascade Forward Backpropagation are at the input and the next layer. In the hidden layer, it has weights coming from the input. The second layer and so on have weights derived from the input and the previous layer. The bias is added in all layers. In the end, it is namely output layer [15]. This will be affected by increasing the weight of the network following the neurons in the input layer.

The cascade forward backpropagation model is employing backpropagation algorithms to improve weights. The sigmoid and pure linear transfer function threshold function is used to reach the peak condition. The deflection between target and output results in an error. It is multiplied by the output derivative of the activation function. Weights will be stored and become candidates in hidden units on the network.

The equation Cascade Forward Backpropagation architecture from figure 3.

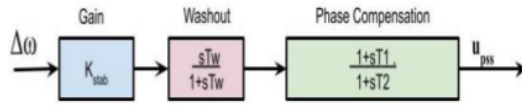

Fig. 2. The Block Diagram of PSS

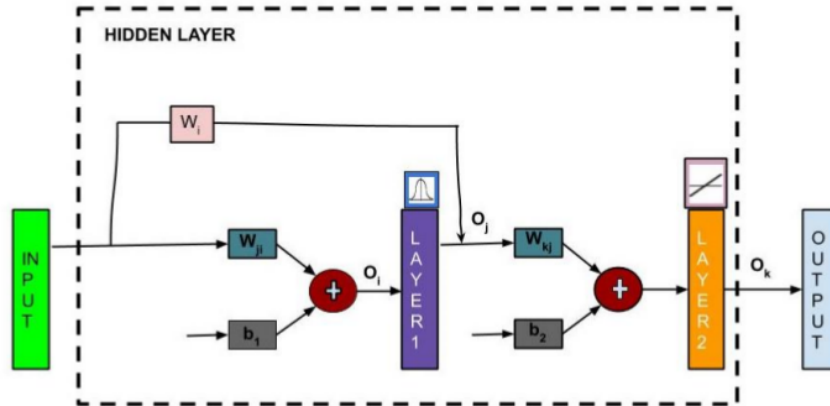

Fig. 3. Cascade Forward Backpropagation Neural Network Architecture.

Layer 1

$$O_i(t) = \sum_{j=1}^i W_{ji} p^j + b_i \quad (1)$$

$$O_j(t) = \int O_i(t) \quad (2)$$

Layer 2

$$O_k(t) = \int (b_k + \sum_{j=1}^k W_{kj} \cdot \int O_i(t) \cdot \sum_{i=1}^j f^i W_i p^i) \quad (3)$$

One of the methods to measure the difference between the output value and the target is Mean squared error (MSE). The math formula is as follows:

$$MSE = \frac{1}{n} \sum_{k=1}^n (x_k(t) - O_k(t))^2 \quad (4)$$

TABLE I. SYMBOL OF CFBNN

Symbol	Parameter
W_{ji}	Weight of input
W_{sj}	Weight input for hidden layer
P^1	Input
O_j	Output of Hidden Layer (layer 1)
O_k	Network Output
W_{kj}	Weight of hidden layer
b_i	Bias

The CFB recognize wave the output and attempt to restrain the overshoot. If it has appeared error, the wave is brought back to NN for the learning process again. It has one input $\Delta\omega$. $\Delta\omega$ is the output system for input CFBNN. It is for training. The Formula is :

$$Xi(t) = [\Delta\omega] \quad (5)$$

Where ω is the angular velocity in rad/s. CFBNN-PSS has installed to the system after the mapping process finished

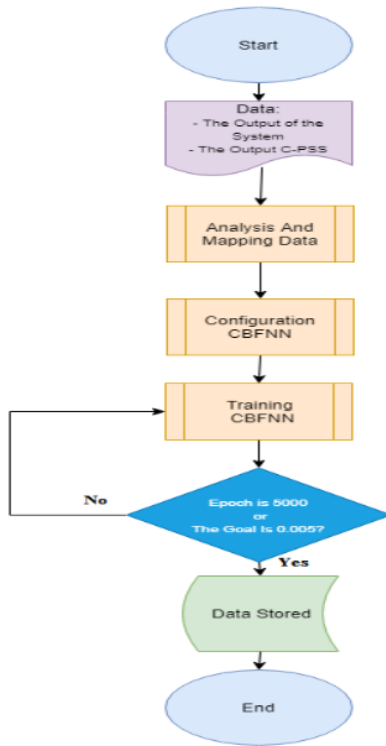

Fig. 4. Flowchart Of Design CFBNN-PSS

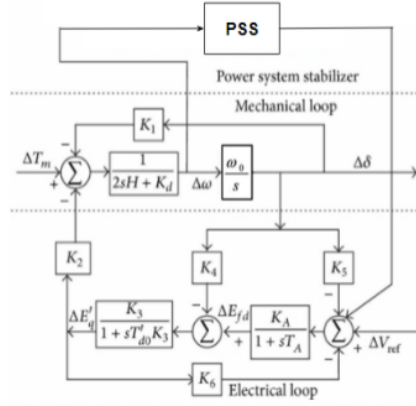

Fig. 5. Single Machine Block Diagram.

TABLE II. CASCADE FORWARD BACKPROPAGATION PARAMETERS

Syntax	Parameter
Hidden Layer	2
Epoch	5000
LR	0.1
MC	0.5

IV. PROPOSED CFBNN FOR TUNING PSS

The Flowchart of CFBNN training can be seen in Figure 4. The first step is making system modeling. The Data is taken from the system output which is angular frequency. The data obtained is analyzed and mapped. Then, The CFBNN training and configuration is conducted. The CFBNN training will stop if the epoch reaches 5000 or the goal crosses 0.005.

V. RESULTS AND DISCUSSION

The generator model using Heffron-Philips can be visible in Figure 5. The Heffron-Philips model consists of Mechanical loop, and electrical loop. The detail of variables can be seen Table 3. The training data to decrease overshoot is the output system with variable speed including the interference.

TABLE III. SYMBOL LIST OF ELECTRICAL LOOP

Parameter	Function
$K_2 - K_6$	Heffron-Phillips model coefficients
K_A	DC gain of the AVR
T_A	Time constant of the AVR
ΔV_{ref}	Reference voltage of the AVR
ΔE_{fd}	Field winding voltage that from AVR output

TABLE IV. SYMBOL LIST OF MECHANICAL LOOP

Parameter	Function
K_1	Heffron-Phillips model coefficients
H	Shaft inertia constant
K_D	Damping constant
T_m	Mechanical torque from turbine
ω	Rotor angular speed
δ	Rotor angle

The results of the CFBNN training can be seen in Figure 6. The CFBNN is takes 15 seconds for training, the algorithm used by levenberg-marquardt, the required iteration is 204 of 5000. The goal limit is fulfilled which is 0.00515. Figure 7 and Figure 8 are response from angular frequency and rotor angle with injected 1 p.u load.

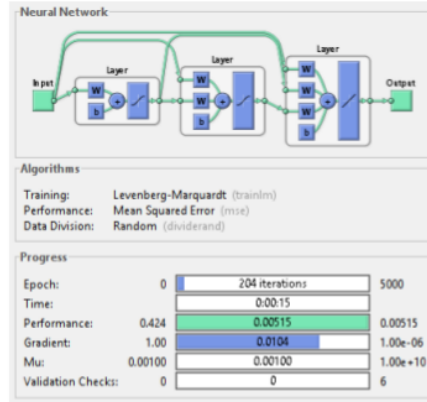

Fig. 6. Training CFBNN

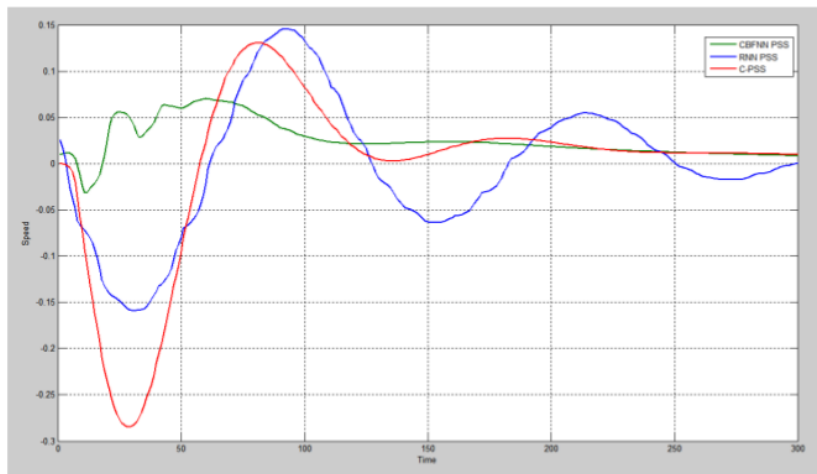

Fig. 7. Angular Frequency Comparison

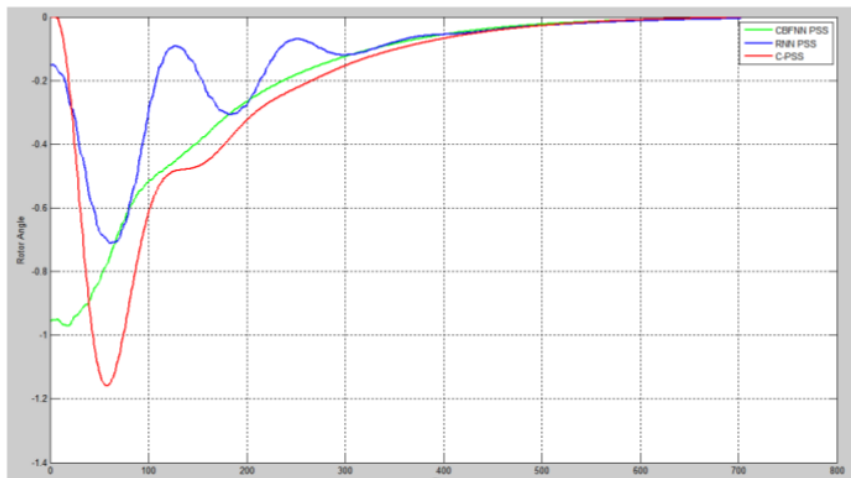

Fig. 8. Rotor Angle Comparison

Figure 7 and Figure 8 are response from angular frequency and rotor angle with injected 1 p.u load. In Table 5, CFBNN PSS can reduce 0.25822 p.u the surprises wave of the angular frequency from 0.2844 p.u to 0.02618 p.u. CFBNN can cut down the exceed wave of rotor angle to 0.97 pu. It can be seen in Table 6.

TABLE V. ANGULAR FREQUENCY OVERSHOOT

Type PSS	Over shoot (p.u)	Time Over shoot (ms)	Time Settling (ms)
Conventional PSS	0.2844	28	600
RNN PSS	0.1587	33	588
CFBNN PSS	0.02618	13	567

TABLE VI. ROTOR ANGLE OVERSHOOT

Type PSS	Overshoot (p.u)	Time Overshoot (ms)
Conventional PSS	1.158	59
RNN PSS	0.71	63
CFBNN PSS	0.97	18

VI. CONCLUSIONS

The CFBNN design in this study has 2 hidden layers with sigmoid training. Training of The output is using linear transfer function. The CFBNN PSS is installed in Single Machine. It is competent to fix the performance of the plant. The CFBNN is showed that the CFBNN PSS can present preferably opposed C-PSS. It has shown that PSS based on CFBNN is preferable for PSS under disturbances. From the test, it was found that the proposed method had a better ability to suppress swings. The CFBNN-PSS can turn down the peak of angular frequency until 90.7%. The CFBNN method has faster time-settling at angular frequency. It is 33 seconds faster than C-PSS. On other hand, RNN-PSS is only capable of 22 seconds compared to C-PSS. The CFBNN method has faster time-settling compared to RNN. It is about 11 second.

REFERENCES

[1] Marizan S, Hayfaa MH, Rosli O, Zulhisyam S. " Dynamic Stability Analysis of Generator with Power System Stabilizers Using Matlab Simulink," Indonesian Journal of Electrical Engineering and Computer Science, Vol.2(3), pp 501-509, 2016. <http://10.11591/ijeecs.v2.i3.pp501-509>

[2] CR Makkar, L Dewan. " Simultaneous Coordination of Power System Stabilizer and UPFC for Improving Dynamic Stability of Multimachine System," IEEE 6th India International Conference on Power Electronics (IICPE), pp 82-86, 2014. <http://10.1109/IICPE.2014.7115751>

[3] A Kharrazi. " Tuning of Power System Stabilizer in Single Machine Infinite Bus (SMIB) using Genetic Algorithm and Power Factory

Modal Analysis," Australasian Universities Power Engineering Conference (AUPEC), 2015. <http://10.1109/AUPEC.2015.7324846>

[4] Mostafa HE, El-Sharkawy MA, Emary AA, Yassin K. " Design And Allocation Of Power System Stabilizers Using The Particle Swarm Optimization Technique For An Interconnected Power System," Int J Electr Power Energy Syst, Vol: 34, pp 57-65, 2012. <https://doi.org/10.1016/j.ijepes.2011.09.005>

[5] Dhanraj, C, SWamkar.A Gupta, Niazi K.R, Bansal R.C. " Optimal Tuning Of Multimachine Power System Stabilizer Using Cuckoo Search Algorithm," International Federation of Automatic Control, pp 143-148, 2015. <https://doi.org/10.1016/j.ifacol.2015.12.368>

[6] Elshafei, A.L., El-Metwally, K.A., Shaltout, A.A. " A Variable-Structure Adaptive Fuzzy-Logic Stabilizer For Single And Multi-Machine Power Systems," Control Eng. Pract. 13 (4): pp 413-423, 2005.

[7] Eslami, M., Shareef, H., Khajehzadeh, M. "Optimal Design Of Damping Controllers Using A New Hybrid Artificial Bee Colony Algorithm," Int. J. Electr. Power Energy Syst. Vol. 52, pp 42-54, 2013. <https://doi.org/10.1016/j.ijepes.2013.03.012>

[8] Khodabakhshian A, Hemmati R. " Multi-Machine Power System Stabilizer Design By Using Cultural Algorithms," Int J Electr Power Energy Syst, Vol. 44, pp 571-80, 2013. <https://doi.org/10.1016/j.ijepes.2012.07.049>

[9] K. Sundareswaran, and S. Razia Begum. " Genetic tuning of a power system stabilizer," European Transactions on Electrical Power, Vol.4(3), pp. 151-160, 2004. <https://10.1002/etep.11>

[10] Aribowo,W. " Focused Time Delay Neural Network For Tuning Automatic Voltage Regulator," EMITTER International Journal of Engineering Technology, Vol.7(1), pp . 34-43, 2017. <http://10.24003/emitter.v7i1.31>

[11] Vinayak K Patki, S. Shrihari, B. Manu. " Water Quality Prediction In Distribution System Using Cascade Feed Forward Neural Network," International Journal of Advanced Technology in Civil Engineering, 2(1), pp: 2231 -5721, 2013.

[12] Nazir, A. " A comparative study of Cascaded Forward Back Propagation and Hybrid SOFM-CFBP Neural Networks based Intrusion Detection Systems," International Journal of Scientific & Engineering Research, Vol. 4(6), pp 2447-2453, 2013.

[13] Sumit G, Gyandera KG. " Cascade and Feedforward Backpropagation Artificial Neural Network Models For Prediction of Sensory Quality of Instant Coffee Flavoured Sterilized Drink," Canadian Journal on Artificial Intelligence, Machine Learning and Pattern Recognition, Vol. 2(6). pp 78-82, 2011.

[14] D. P. Gaikwad, Ravindra R Thool. " Intrusion Detection System using Cascade Forward Neural Network with Genetic Algorithm Based Feature Selection," AISSMS College of Engineering, Pune, SGGAI0 Technology and Engineering, Nanded. Vol. 3(3). pp 13-19, 2014.

[15] Supriya Narad , Pallavi Chavan. " Cascade Forward Back-propagation Neural Network Based Group Authentication Using (n, n) Secret Sharing Scheme," International Conference on Information Security & Privacy (ICISP2015), 11-12 December 2015, Nagpur, INDIA, 2015. <https://doi.org/10.1016/j.procs.2016.02.032>

[16] Aribowo,W. " Tuning For Power System Stabilizer Using Distributed Time-delay Neural Network," Sinergi, Vol. 22(3), pp . 205-210, 2018.

ORIGINALITY REPORT

5%

SIMILARITY INDEX

1%

INTERNET SOURCES

4%

PUBLICATIONS

0%

STUDENT PAPERS

PRIMARY SOURCES

1

Advances in Intelligent Systems and Computing, 2016.

Publication

1%

2

Khodabakhshian, Amin, and Reza Hemmati. "Multi-machine power system stabilizer design by using cultural algorithms", International Journal of Electrical Power & Energy Systems, 2013.

Publication

1%

3

Ali Azizivahed, Hossein Narimani, Mehdi Fathi, Ehsan Naderi, Hamid Reza Safarpour, Mohammad Rasoul Narimani. "Multi-objective dynamic distribution feeder reconfiguration in automated distribution systems", Energy, 2018

Publication

<1%

4

Suraj Ankush Dahat, Mandar Sudhir Isasare, Rahul Padmakar Argelwar, Tabish Shanu. "Co-ordinated tuning of PSS with TCSC damping controller in single machine power system using PSO", 2018 2nd International Conference on Inventive Systems and Control (ICISC), 2018

<1%

5

Muhammad Kashif, Yunjian Peng, Weijie Sun. "A Comparison Study on Intelligent Control Strategies of Power System Stabilizers", 2018 International Conference on Power System Technology (POWERCON), 2018

Publication

6

www.pecteam.in

Internet Source

7

M A Syakur, B K Khotimah, E M S Rochman, B D Satoto. "Integration K-Means Clustering Method and Elbow Method For Identification of The Best Customer Profile Cluster", IOP Conference Series: Materials Science and Engineering, 2018

Publication

8

Arun Patel, S. K. Katiyar, Vishnu Prasad. "Bathymetric Mapping of Bhopal City Lower Lake Using IRS-P6: LISS-4 Imagery and Artificial Neural Network Technique", Journal of the Indian Society of Remote Sensing, 2016

Publication

9

A. Rubaai, A.R. Ofoli, D. Cobbinah, M.D. Kankam. "Two-Layer Supervisory Controller-Based Thyristor-Controlled Braking Resistor for Transient Stability Crisis", IEEE Transactions on Industry Applications, 2005

<1%

<1%

<1%

<1%

<1%

10

S Paul, P K Roy. "Optimal design of power system stabilizer using oppositional gravitational search algorithm", 2014 1st International Conference on Non Conventional Energy (ICONCE 2014), 2014

<1%

Publication

Exclude quotes On

Exclude matches Off

Exclude bibliography On

widi aribowo - icvee 2020 revisi

GRADEMARK REPORT

FINAL GRADE

/100

GENERAL COMMENTS

Instructor

PAGE 1

PAGE 2

PAGE 3

PAGE 4

PAGE 5
